

Room air quality sensor MLEVB

Air quality sensor with measuring transducer 0–10 V and room temperature measuring transducer 0–10 V



Technical data

Operating voltage:	24 V \approx /V \sim , 50 Hz
Current consumption:	approx. 30 mA
Measuring range:	0 ... 4000 ppm VOC
Medium:	Air
Output signal:	0 ... 10 V: 0 ... 4000 ppm VOC 0 ... 10 V: 0 ... 30 °C
Measuring accuracy:	\pm 300 ppm VOC
Reproducibility:	> 95 %
Reaction time t_{90}:	< 30 s < 3 min diffusion time
Temperature range:	0 ... 50 °C
Storage temperature:	-10 ... 50 °C
Humidity:	max 95 %, non condensing
Degree of protection:	IP 30
Safety and EMC:	acc. to DIN EN 60730
Housing:	plastic (ABS)
Colour:	pure white, similar to RAL 9010
Electrical connections:	terminal screws 0.25 ... 1.5 mm ²
Weight:	approx. 130 g

Application

The air quality sensor serves for the requirement-dependant ventilation of living spaces, office premises, meeting rooms, hotels or restaurants. It serves for the quantitative evaluation of the pollution of the air in rooms with gases, such as used up breathing air, tobacco some, solvent vapours, cleaning agents and car fumes.

Room air captured by the sensor is transformed into a 0 – 10 V output signal. A minimum value at output is interpreted as clean air, while a maximum value is evaluated as highly contaminated. In addition, the room temperature in the range of 0 – 30 °C is continuously recorded and output as a 0 – 10 V signal.

This air quality sensor is not suited for the execution of a selective CO₂ measurement.

See page 118 for the compatible microprocessor controller, JDU-210.

The MLEVB-042.000 replaces the RLS models.

Important:
The air quality sensor must not be used for any safety-relevant applications, no matter of what kind.

Please pay regard to the EMC directives. Avoid parallel laying of sensor line and mains supply cables or use shielded sensor lines.

Type	Item No.	Output	PG
MLEVB-042.000	G 9230070	Air quality sensor with measuring transducer for VOC and room temperature	III

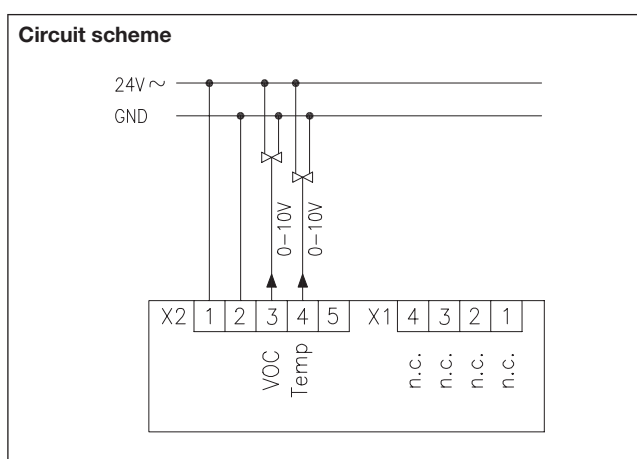
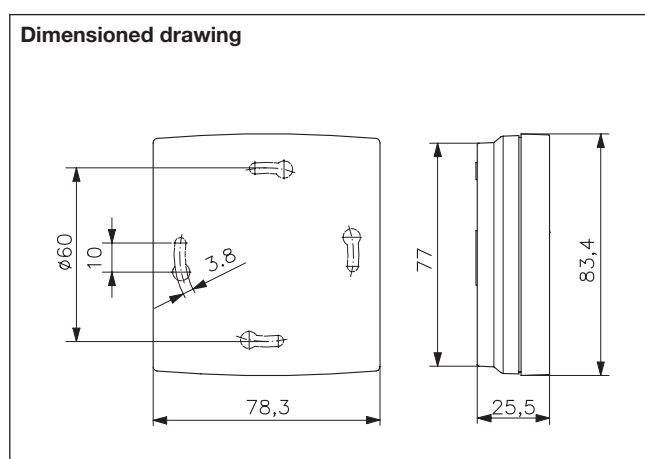

Following a restart or power failure, a 100% signal is output for 20 minutes to ensure maximum ventilation. During this time, the air quality sensor assumes a current baseline VOC value of 450 ppm. The resulting output signal of 1.125 V (approx. 11%) ensures a basic level of ventilation. As the air quality improves, the baseline value is automatically corrected.