

Type ME 01

Applications

Electronic manometer with ceramic measuring cell for pressure or vacuum measurements. For on-site read-out and remote transfer of measurements. Measuring ranges from 0...1.0 bar to 0...400 bar.

For many applications in the following fields:

- Control engineering
- Process control
- Environmental engineering
- Machine and system construction

Main features

- Direct measuring sensor without transfer fluid
- High degree of protection against vibration
- High accuracy
- Over-pressure safety
- Low hysteresis



Dimensioned Drawing

Construction and functioning

A ceramic measuring cell is used as a pressure sensor. The highly robust ceramic materials used allows the system to be used in conjunction with aggressive media.

A resistive bridge is located on the side of the system which comes into contact with the medium. When pressure is applied, the diaphragm changes form within its elastic range. Simultaneously, the resistive values of the bridge change in proportion with and to the pressure to be measured. These values are converted by the internal electronics and displayed.

A standard 0...20 mA electric signal is available to transfer values to a remote position via three-wire system.

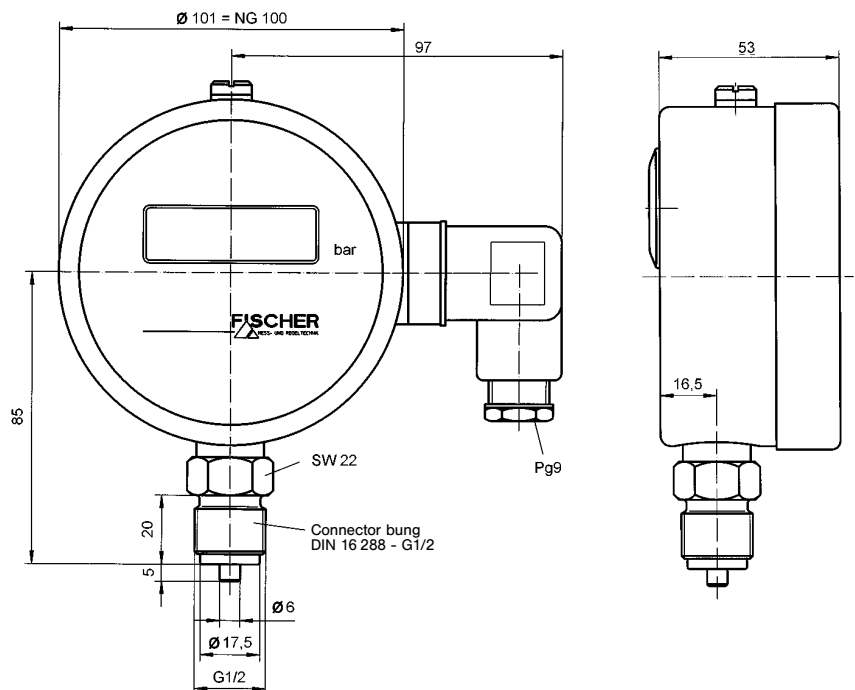

ME 01 Technical Data

Measuring range _____	0...1 bar to 0...400 bar (ref. ordering code)
Over-pressure safety _____	2x measuring range to 60 bar, 1.5x measuring range over 60 bar
Linearity _____	± 1% of measuring range
Hysteresis _____	smaller 0.5% of measuring range
Permissible ambient temp. _____	0 to 60°C
Permissible medium temp. _____	0 to 85°C
Pressure connection _____	G1/2 bung in accordance to DIN 16 288
Electrical connection _____	90 degree connector DIN 43 650
Protection class _____	IP 54 in accordance with DIN 40 050

Materials

Wetted parts _____	Chrome-Nickel-Steel 1.4305, Ceramic, Viton
Housing _____	Chrome-Nickel-Steel 1.4301
Front glass _____	Safety glass

Electrical data

Power supply _____	24 V DC ± 20%
Output signal _____	0...20 mA, independent from digital read-out
Electrical connection _____	3-wire
Load at nominal voltage _____	500 Ohm
Current limitation _____	approximately 30 mA
Temp. drift at zero point _____	0.4% FS / 10°K
Temp. drift over meas. range _____	0.1% FS / 10°K

Electrical connections

Three-wire-connection

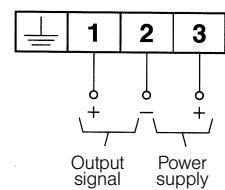

Ordering Code

Digital Manometer

Type ME 01

0 8 7 A H 9

Measuring ranges

0... 1 bar	T 0 2
0... 1.6 bar	T 0 3
0... 2.5 bar	T 0 4
0... 4 bar	T 0 5
0... 6 bar	T 0 6
0... 10 bar	T 0 7
0... 16 bar	T 0 8
0... 25 bar	T 0 9
0... 40 bar	T 1 0
0... 60 bar	T 1 1
0... 100 bar	T 1 2
0... 160 bar	T 1 3
0... 250 bar	T 1 4
0... 400 bar	T 1 5
-1... 0 bar	T 3 1
-1... 0.6 bar	T 3 2
-1... 1.5 bar	T 3 3
-1... 3 bar	T 3 4
-1... 5 bar	T 3 5
-1... 9 bar	T 3 6
-1... 15 bar	T 3 7

Construction

Standard

Pressure connection

Connector bung G 1/2 A (acc. to DIN 16 288)

Electrical output signal

0...20 mA, three-wire-connection
4...20 mA, three-wire-connection (on request)

Electrical connection

Plug connector acc. to DIN 43 650

Power supply

24 V DC ± 20%